

THE INFORMATION CONTAINED IN THIS DRAWING IS THE SOLE PROPERTY OF ALTIMATE MEDICAL. ANY REPRODUCTION IN PART OR WHOLE WITHOUT THE WRITTEN PERMISSION OF ALTIMATE MEDICAL IS PROHIBITED.

REVISIONS			
REV:	DESCRIPTION:	ECO #:	DATE:

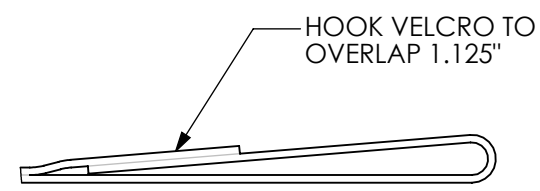

A (1 : 1.5)

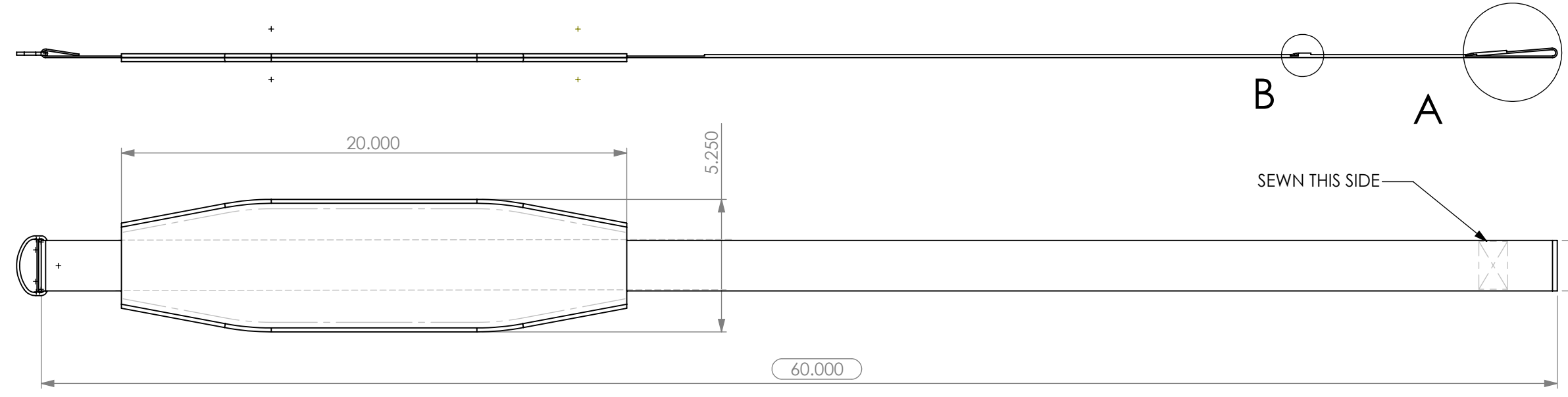
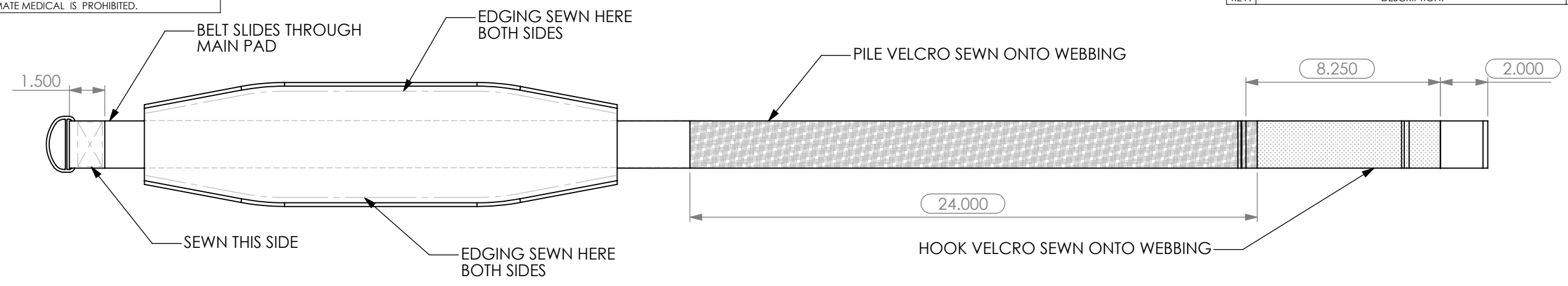
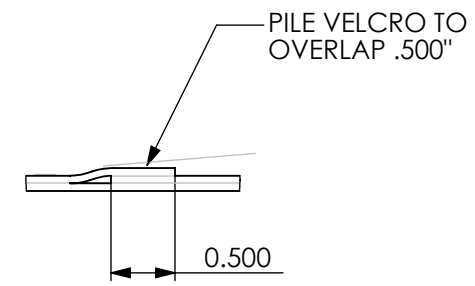

B (1 : 1.5)

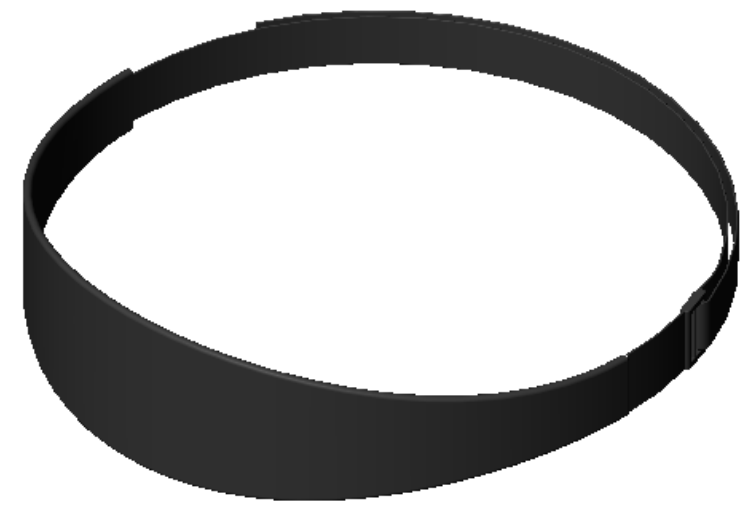

IF BOX CONTAINS AN "X", SEE NOTES THAT APPLY TO EACH SUBJECT. <input type="checkbox"/> SEE SHIPPING INSTRUCTIONS <input type="checkbox"/> RECEIVING INSPECTION <input type="checkbox"/> SEE ENVIRONMENTAL INSTRUCTIONS	APPROVED:	DATE:	UNLESS OTHERWISE SPECIFIED DIMENSIONS ARE IN INCHES. TOLERANCES AND SPECS. ARE: DECIMALS .X ± .1 ANGLES .X ± .5° .XX ± .03 .XXX ± .015 HOLE SIZE TOLERANCE: (+.005/-.000) BREAK EDGES .005 - .015 CMFR DRILLED HOLES .03 X 45°	ALTIMATE MEDICAL, INC. PO BOX 180 - 262 WEST FIRST STREET - MORTON, MN 56270 PHONE (507) 697-6393 FAX (507) 697-6900 DESCRIPTION: S. CHEST RESTRAINT SIZE DWG. NO. 51601 REV. 000 SCALE = 1:5 CAD FILE NAME: 51601 SHEET 1 OF 1	
	DRAWN:	DATE: 11/16/1999			MATERIAL: FABRIC
	EXPIRATION DATE:				FINISH: UNFINISHED CODE: UPSTRY