

THE INFORMATION CONTAINED IN THIS DRAWING IS THE SOLE PROPERTY OF ALTIMATE MEDICAL. ANY REPRODUCTION IN PART OR WHOLE WITHOUT THE WRITTEN PERMISSION OF ALTIMATE MEDICAL IS PROHIBITED.

REVISIONS				
REV:	DESCRIPTION:	ECO #:	DATE:	APPROVED:
01	ADDED SPRING PINS, CHANGED KNOB TO 40MM LONG	-	4/21/05	GJR
000	NEW RELEASE.	05-ECO-001	7/12/05	JVS
A	REVISED NG10164, NG10165 & NG20010 TO REV A	-	2/15/07	JVS
	ALSO REPLACED NG20044 WITH NG10775	-	2/15/07	JVS
B	REVISED NG20010. ADDED ITEMS 80103 AND 600220.	DCR-00646	1/26/10	MWL
C	REVISED NG10243	DCR-00935	7/6/12	TJF

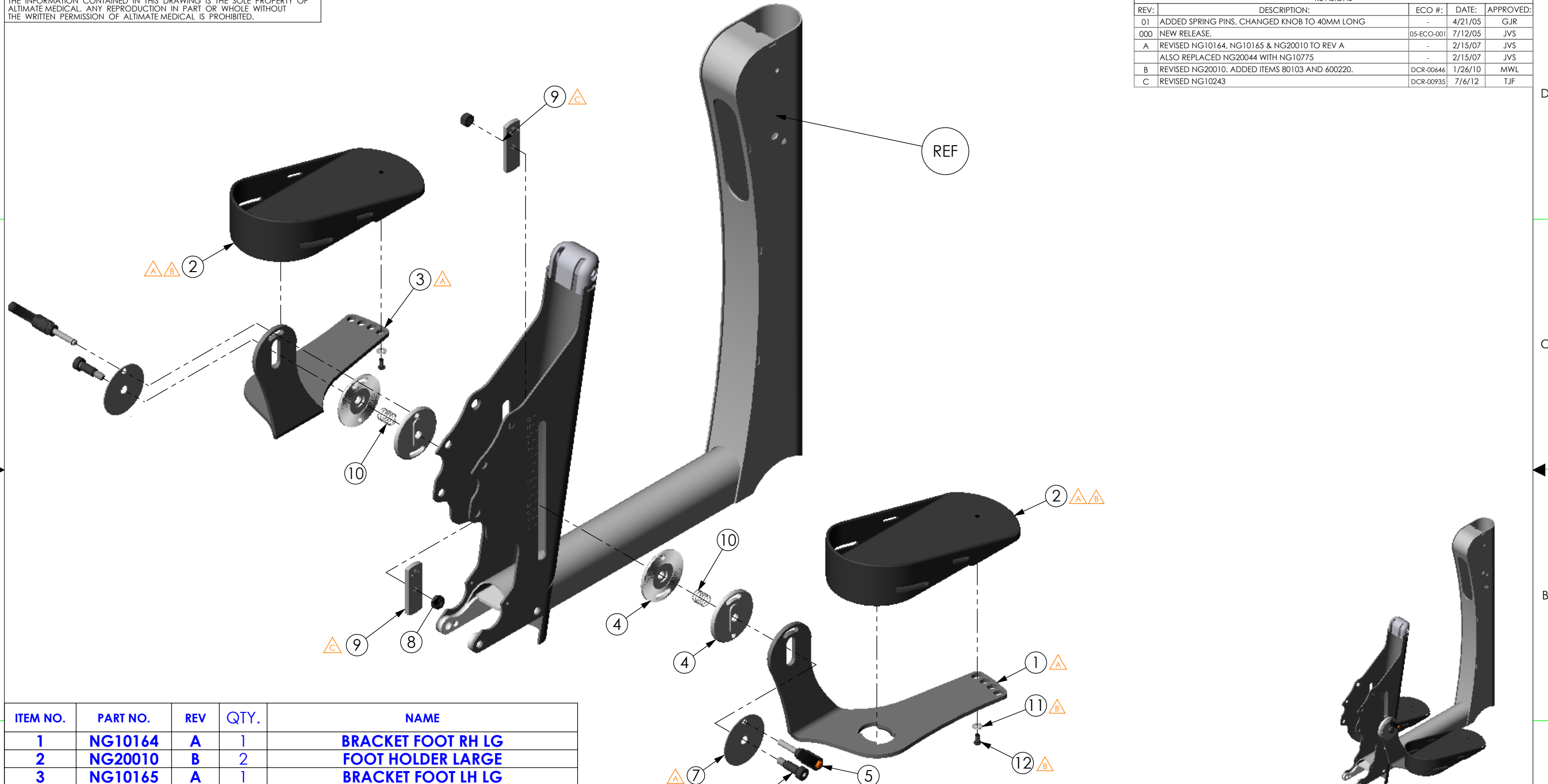

ITEM NO.	PART NO.	REV	QTY.	NAME
1	NG10164	A	1	BRACKET FOOT RH LG
2	NG20010	B	2	FOOT HOLDER LARGE
3	NG10165	A	1	BRACKET FOOT LH LG
4	NG10179	B	4	CLAMP TOOTHED
5	600156	000	2	CLAMP LEVER 8mm X 40mm
6	600114	000	2	BOLT M12 X 25 SHOULDER
7	NG10775	000	2	COVER METAL
8	600010	000	2	NUT M10 X 1.5 NYLON LOCK
9	NG10243	A	2	LUG FOOT ADJUSTMENT
10	600174	000	2	FOOT REST SPRING
11	80103	-	2	FLAT WASHER
12	600220	000	2	BOLT BTN SHCS M6 X 1.0 - 12

**NOTE:**  
1. ASSEMBLE FOOT RESTS BEFORE INSTALLING HYDRAULIC OR ELECTRIC ACTUATOR.

IF BOX CONTAINS AN "X", SEE NOTES THAT APPLY TO EACH SUBJECT.		APPROVED:	DATE:	UNLESS OTHERWISE SPECIFIED DIMENSIONS ARE IN INCHES. TOLERANCES AND SPECS. ARE: DECIMALS .X ± .1 .XX ± .03 .XXX ± .015 HOLE SIZE TOLERANCE: (+.005/- .000) BREAK EDGES .005 - .015 CMFR DRILLED HOLES .03 X 45°	ALTIMATE MEDICAL, INC. PO BOX 180 - 262 WEST FIRST STREET - MORTON, MN 56270 PHONE (507) 697-6393 FAX (507) 697-6900
<input type="checkbox"/> SEE SHIPPING INSTRUCTIONS	<input type="checkbox"/> RECEIVING INSPECTION	DRAWN: MWL	DATE: 2/9/05		
<input type="checkbox"/> SEE ENVIRONMENTAL INSTRUCTIONS		MATERIAL:	FINISH: -		
		CODE: ASMBLY			
		DESCRIPTION: FOOT ASMBLY LG		SIZE DWG. NO. NG50015	REV. C
		SCALE = 1:5		CAD FILE NAME: NG50015	SHEET 1 OF 1