

THE INFORMATION CONTAINED IN THIS DRAWING IS THE SOLE PROPERTY OF ALTIMATE MEDICAL. ANY REPRODUCTION IN PART OR WHOLE WITHOUT THE WRITTEN PERMISSION OF ALTIMATE MEDICAL IS PROHIBITED.

REVISIONS				
REV:	DESCRIPTION:	ECO #:	DATE:	APPROVED:
000	NEW RELEASE	DCR-00292	1/2/07	JVS
A	REVISED NG20104 AND NG10869. ADDED NG50331 AND 600059.	DCR-00446	7/28/08	MWL
A	REMOVED 600139.	DCR-00446	7/28/08	MWL
B	REVISED NG10054. ADDED ITEMS 600323, 600058, NG20002 AND	DCR-00462	11/3/08	MWL
B	600026. REPLACED 600280 WITH 600422.	DCR-00462	11/3/08	MWL
C	REVISED NG10054 REV D	DCR-00591	9/08/09	JVS
D	REVISED NG10869 REV B	DCR-00642	1/15/10	JVS

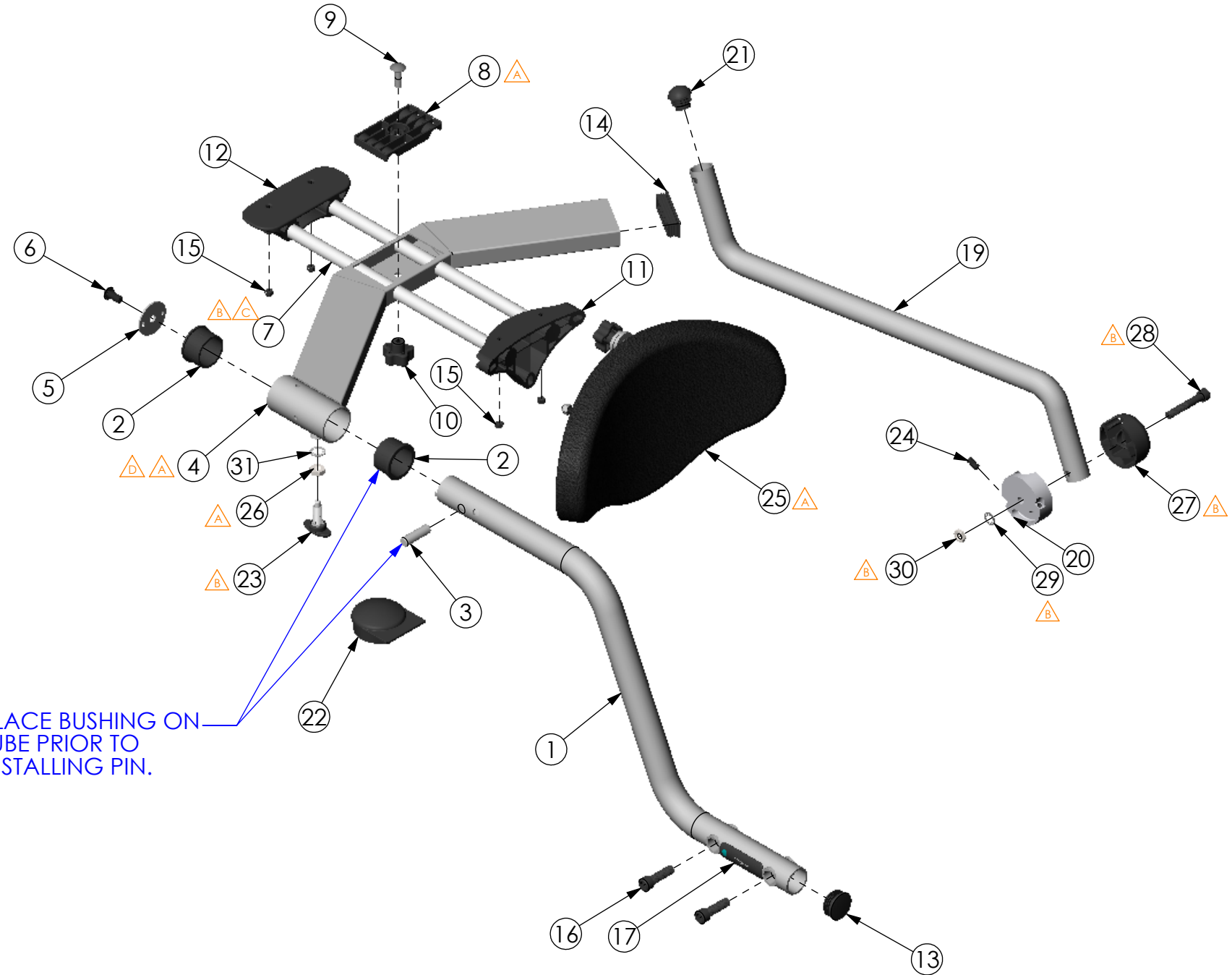
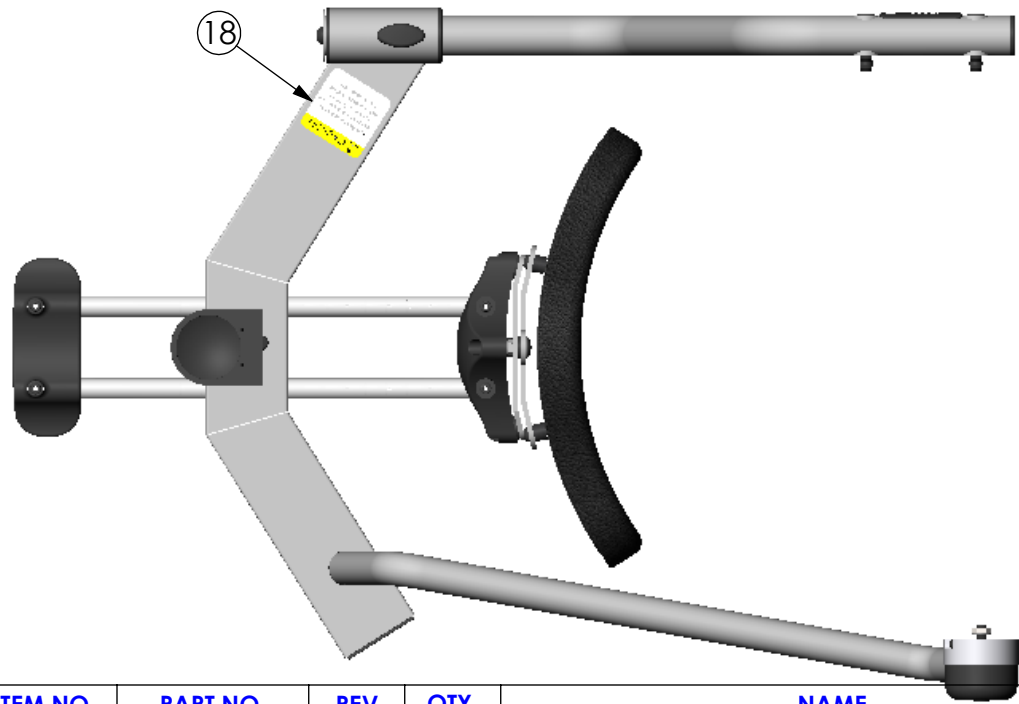

PLACE BUSHING ON TUBE PRIOR TO INSTALLING PIN.

ITEM NO.	PART NO.	REV	QTY.	NAME
1	NG11016	000	1	WELDMENT TABLE SUPPORT XT
2	NG20041	B	2	BUSHING STS TABLE
3	NG10882	000	1	PIN SHADOW SUPPORT TRAY
4	NG10869	B	1	BRACKET MOUNT TABLE LH
5	NG10879	000	1	CAP END SHADOW SUPPORT TRAY
6	600116	-	1	BOLT M10 X 1.5 - 20 BTN SHCS
7	NG10054	D	2	TUBE TABLE ADJUSTMENT
8	NG20104	A	1	CLAMP SHADOW SUPPORT TRAY
9	600091	000	1	BOLT M8 X 1.25 - 30 CARRIAGE
10	600132	000	1	KNOB FEMALE 5 POINT M8 X 1.25
11	NG20005	000	1	CLAMP NYLON TABLE REAR
12	NG20006	000	1	CLAMP NYLON TABLE FRONT
13	600088	000	1	CAP 1.50D 14-20GA
14	600086	000	1	CAP RECT 1" X 3" X 14-20GA
15	600008	000	4	NUT M6 X 1.0 NYLON LOCK
16	600073	00	2	SHCS M12X1.75-40
17	NG40024	000	1	LABEL .75 x 2.875 EVOLV SHADOW
18	NG40019	A	1	LABEL 2.50 X 2.50 CAUTION STS
19	NG11018	000	1	TUBE SUPPORT ARM XT
20	NG10730	000	1	DISC PIVOT INSIDE ALUM.
21	600082	000	1	BALL CAP 1.25D 14-23 GA
22	NG20015	000	1	FRAME CAP
23	600422	000	1	PLUNGER INDEXED 8mm
24	600283	000	1	SCREW SET M8 X 1.25 - 16
25	NG50331	A	1	ASSEMBLY ADJUSTABLE PAD BRACKET
26	600059	000	1	NUT JAM M12 X 1.75
27	NG20002	000	1	DISC PIVOT OUTSIDE
28	600026	000	1	SHCS M10 X 1.5-60
29	600323	000	1	WASHER LOCK 10mm INTERNAL TOOTH
30	600058	000	1	NUT JAM M10 X 1.5
31	80946	-	1	WASHER

IF BOX CONTAINS AN "X", SEE NOTES THAT APPLY TO EACH SUBJECT. <input type="checkbox"/> SEE SHIPPING INSTRUCTIONS <input type="checkbox"/> RECEIVING INSPECTION <input type="checkbox"/> SEE ENVIRONMENTAL INSTRUCTIONS	APPROVED:	DATE:	UNLESS OTHERWISE SPECIFIED DIMENSIONS ARE IN INCHES. TOLERANCES AND SPECS. ARE: DECIMALS .X ± .1 ANGLES .X ± .5° .XX ± .03 .XXX ± .015 HOLE SIZE TOLERANCE: (+.005/- .000) BREAK EDGES .005 - .015 CMFR DRILLED HOLES .03 X 45°	ALTIMATE MEDICAL, INC. PO BOX 180 - 262 WEST FIRST STREET - MORTON, MN 56270 PHONE (507) 697-6393 FAX (507) 697-6900 DESCRIPTION: TABLE SHADOW DEEP 12" LH SIZE DWG. NO. NG50333 REV. D SCALE = 1:7 CAD FILE NAME: NG50333 SHEET 1 OF 1	
	DRAWN: JVS	DATE: 10/23/07			MATERIAL:
	OPTION NUMBER: -	FINISH: -			CODE: ASMBLY