

THE INFORMATION CONTAINED IN THIS DRAWING IS THE SOLE PROPERTY OF ALTIMATE MEDICAL. ANY REPRODUCTION IN PART OR WHOLE WITHOUT THE WRITTEN PERMISSION OF ALTIMATE MEDICAL IS PROHIBITED.

REVISIONS				
REV:	DESCRIPTION:	ECO #:	DATE:	APPROVED:
000	NEW RELEASE.	DCR-00459	10/27/08	MWL
A	UPDATED NG40000 TO A REV A	DCR-00520	4/15/09	JVS
B	REPLACED 600410 WITH NG40057	DCR-00829	9/16/11	TJF

NOTE:

1. GREEN RING INDICATES MAX. SEAT DEPTH.
2. INSERT SNAP BUTTON 80825 INTO PLACE PRIOR TO DRIVING PIN 600370 INTO TUBE.
3. USE COVER STICKERS ON BOTH SIDES OF TUBE ON ALL FOUR HOLES.
4. PUT BACK ANGLE LABEL ON PUMP HANDLE SIDE OR THE SIDE OF THE HAND PENDANT FOR THE ELECTRIC LIFT.

REFERENCE NG50007

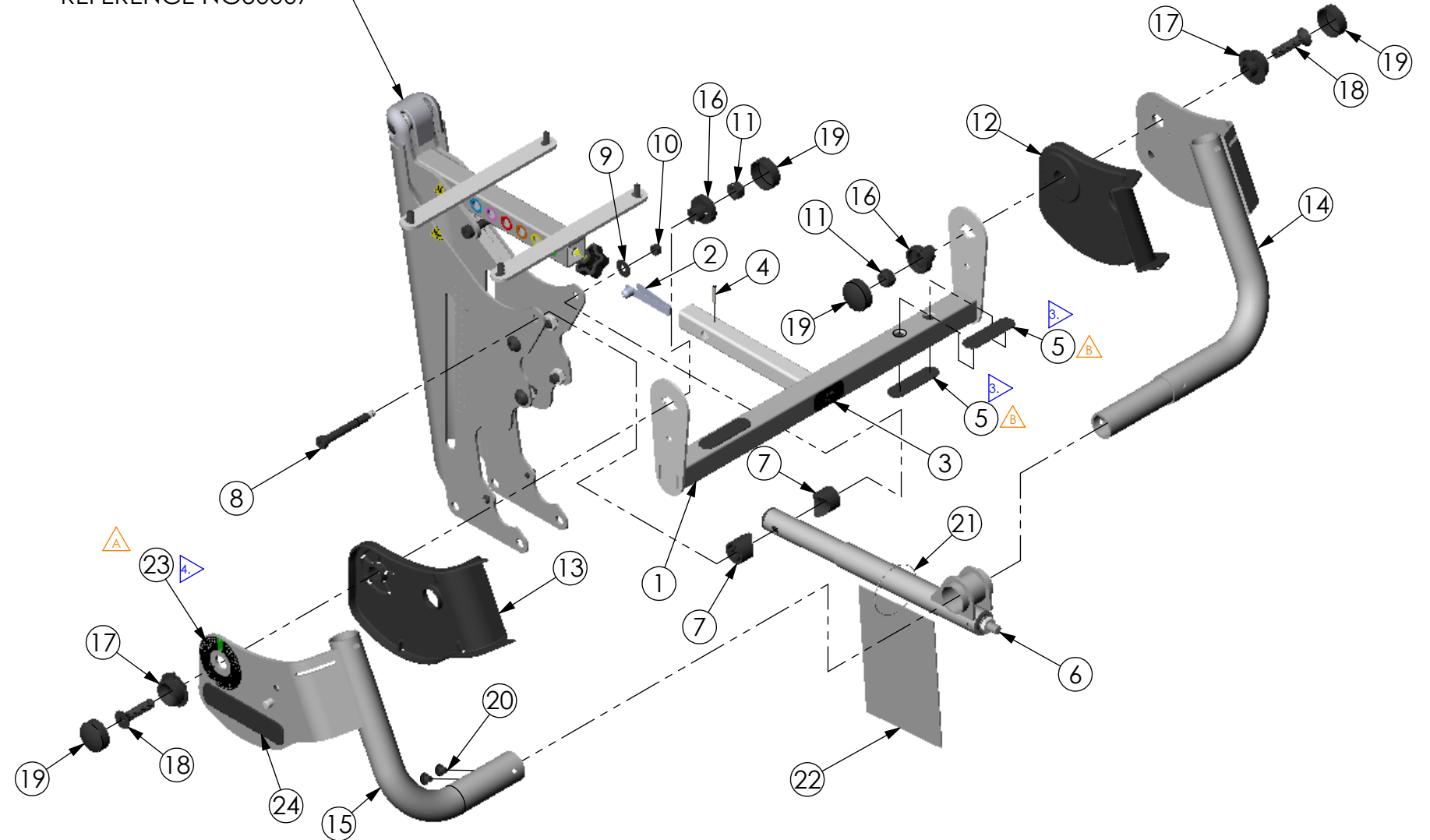

ITEM NO.	PART NO.	REV	QTY.	NAME
1	NG10389	A	1	BRACKET HIP PIVOT MED
2	80825	000	1	SNAP BUTTON
3	NG40029	000	1	LABEL 1.00 X 1.875 EVOLV YOUTH
4	600370	000	1	PIN ROLL 3mm DIA X 24mm LONG
5	NG40057	000	4	HIP PIVOT BRACKET HOLE COVER
6	NG50436	A	1	ASMBLY FOLLOWING ARM YOUTH
7	NG20073	000	2	BUSHING COVERED 1.125 O.D.
8	600218	000	1	BOLT SHOULDER M10 X 70
9	91603	-	1	FLAT WASHER
10	600009	000	1	NUT M8 X 1.25 NYLON LOCK
11	600011	000	2	NUT M12 X 1.75 NYLON LOCK
12	NG20008	000	1	COVER HIP R LG
13	NG20009	000	1	COVER HIP L LG
14	NG10521	000	1	BRACKET HIP MED RH
15	NG10522	000	1	BRACKET HIP MED LH
16	NG20021	B	2	BUSHING C'BORE M12
17	NG20020	C	2	BUSHING C'SINK M12
18	600368	000	2	BOLT M12 X 1.75 - 50 FLT HD SHCS
19	NG20027	000	4	COVER BUSHING
20	600067	000	2	BOLT M8 X 1.25 - 10 BTN SHCS
21	10787	01	1	SNAP TIE 9" LG
22	NG40018	000	1	INSTRUCTIONAL CARD EVOLV
23	NG40000	A	1	DECAL BACK ANGLE ADJ
24	NG40022	000	2	LABEL 1.25 X 5.28 EVOLV HIP

IF BOX CONTAINS AN "X", SEE NOTES THAT APPLY TO EACH SUBJECT. <input type="checkbox"/> SEE SHIPPING INSTRUCTIONS <input type="checkbox"/> RECEIVING INSPECTION <input type="checkbox"/> SEE ENVIRONMENTAL INSTRUCTIONS	APPROVED:	DATE:	UNLESS OTHERWISE SPECIFIED DIMENSIONS ARE IN INCHES. TOLERANCES AND SPECS. ARE: DECIMALS: .X ± .1 .XX ± .03 .XXX ± .015 HOLE SIZE TOLERANCE: (+.005/- .000) BREAK EDGES .005 - .015 CMFR DRILLED HOLES .03 X 45°	ALTIMATE MEDICAL, INC. PO BOX 180 - 262 WEST FIRST STREET - MORTON, MN 56270 PHONE (507) 697-6393 FAX (507) 697-6900 DESCRIPTION: ASMBLY BACK REST YOUTH SIZE DWG. NO. NG50441 SCALE = 1:7 CAD FILE NAME: NG50441 SHEET 1 OF 1	
	DRAWN: MWL	DATE: 9/30/08			MATERIAL:
	EXPIRATION DATE:				FINISH:
					CODE: ASMBLY