

THE INFORMATION CONTAINED IN THIS DRAWING IS THE SOLE PROPERTY OF  
 ALTIMATE MEDICAL. ANY REPRODUCTION IN PART OR WHOLE WITHOUT  
 THE WRITTEN PERMISSION OF ALTIMATE MEDICAL IS PROHIBITED.

REVISIONS				
REV:	DESCRIPTION:	ECO #:	DATE:	APPROVED:
000	NEW RELEASE.	DCR-01002	11/19/12	MWL

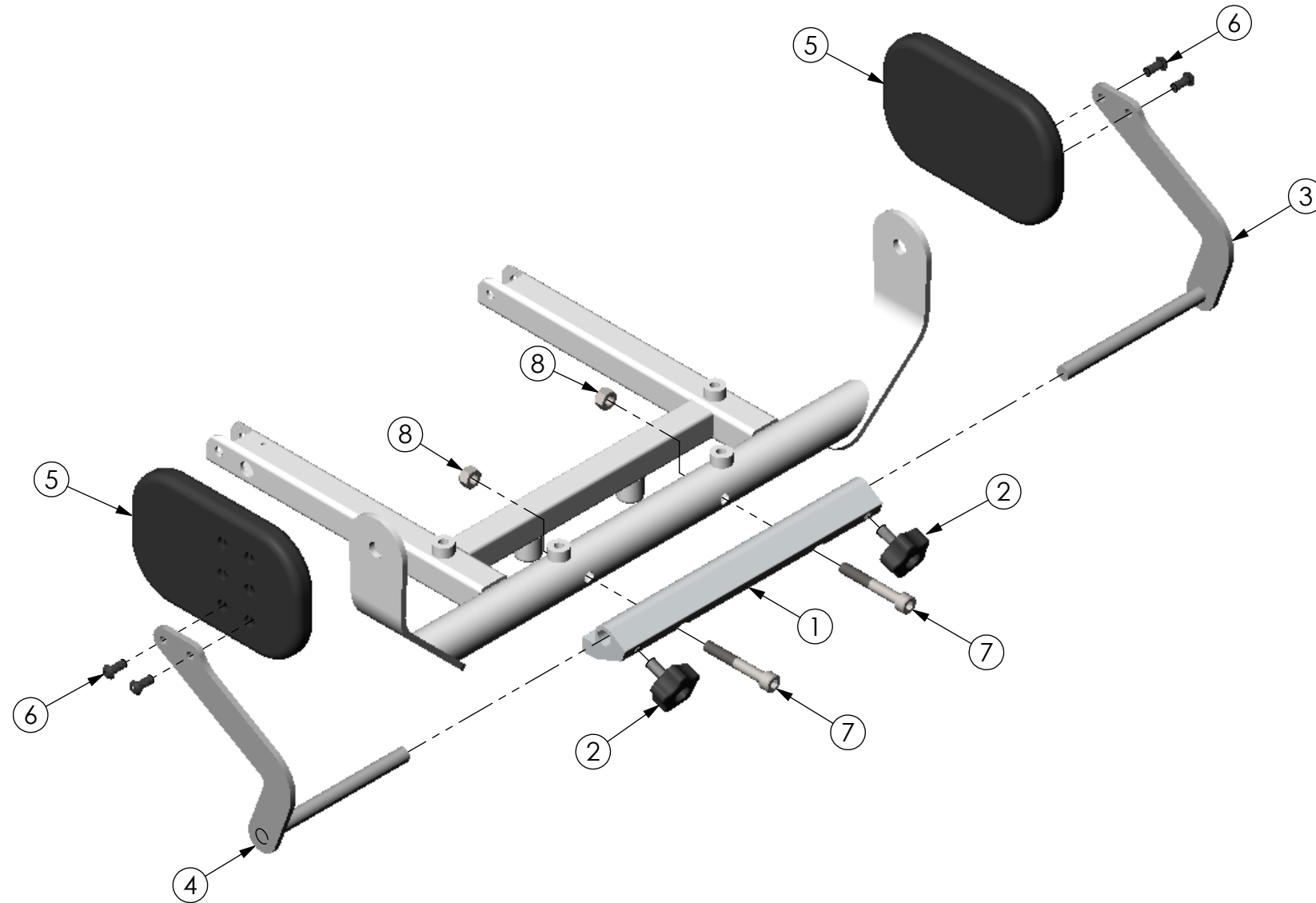

ITEM NO.	PART NO.	REV	QTY.	NAME
1	Y1095	000	1	CLAMP HIP GUIDE
2	600550	000	2	KNOB THUMB M8 X 1.25 - 20
3	Y1100	000	1	BRACKET HIP GUIDE BANTAM MED RH
4	Y1101	000	1	BRACKET HIP GUIDE BANTAM MED LH
5	NG30131	B	2	PAD SUPPORT EVOLV FLAT
6	600374	000	4	BOLT BTN SHCS M6 X 1.0 - 14
7	600084		2	BOLT SHCS M8 X 1.25 - 55
8	600009		2	NUT NYLOCK M8 X 1.25

IF BOX CONTAINS AN "X", SEE NOTES THAT APPLY TO EACH SUBJECT. <input type="checkbox"/> SEE SHIPPING INSTRUCTIONS <input type="checkbox"/> RECEIVING INSPECTION <input type="checkbox"/> SEE ENVIRONMENTAL INSTRUCTIONS	APPROVED:	DATE:	<b>UNLESS OTHERWISE SPECIFIED DIMENSIONS ARE IN INCHES. TOLERANCES AND SPECS. ARE:</b> DECIMALS      ANGLES .X ± .1          .X ± .5° .XX ± .03 .XXX ± .015 HOLE SIZE TOLERANCE: (+.005/-.000) BREAK EDGES .005 - .015 CMFR DRILLED HOLES .03 X 45°	<b>ALTIMATE MEDICAL, INC.</b> PO BOX 180 - 262 WEST FIRST STREET - MORTON, MN 56270 PHONE (507) 697-6393      FAX (507) 697-6900 DESCRIPTION: ASMBLY HIP GUIDES BANTAM MED SIZE DWG. NO. <b>Y5560</b> REV. <b>000</b> SCALE = 1:4      CAD FILE NAME: Y5560      SHEET 1 OF 1	
	DRAWN: MWL	DATE: 11/28/11			MATERIAL:
	EXPIRATION DATE:				FINISH:
					CODE: ASMBLY